

Available with SHOCKWAVE™



Two Post

HEAVY DUTY LIFTS

7,000 TO 20,000 LBS. CAPACITY



SPOTRIO™
HD SERIES LIFTS
16,000 lbs. / 20,000 lbs. capacities

ROTARY LIFT
THE WORLD'S MOST TRUSTED LIFT



Shown: SP020U0T0RD 20,000 lbs. capacity SHOCKWAVE-equipped lift with TRIO arms

www.rotarylif.com

ROTARY TWO-POST LIFTS: ENGINEERED FOR PRODUCTIVITY



Vehicles come in many different shapes and sizes; so do service centers. Rotary two-post are packed with design features you need to be productive, no matter what type of shop you have. With lifting capabilities from 7,000 lbs. to 20,000 lbs., there is a perfect lift combination for any shop bay. And two-post lifts **supercharged with SHOCKWAVE™** are the fastest in the world, helping you keep step with the ever-changing demand of the vehicle service industry.

REINVENTING THE STANDARD

For decades, Rotary Lift has provided technicians with innovative tools to make their lives better. From founder Peter Lunati's first lift in 1925, our groundbreaking ideas have continued to benefit the service industry's focus on greater productivity in the bay. And now Rotary Lift has done it again with the advent of **TRIO™ Series light duty asymmetric and heavy duty symmetric lifts**. TRIO™ lifts employ three-stage capability in a low-profile two-stage arm. With lifting capabilities from 10,000 lbs. to 20,000 lbs. and a variety of adapters you have the perfect lift combination for any shop bay!

Peace of mind

Rotary designers and engineers have developed the most innovative and versatile lift products on the market today setting the bar for durability and attention to safety for years of dependable use. Rotary rigorously cycle tests its lifts and components for at least 20,000 cycles at rated load, giving you a robust, proven and quality tested lift that won't let you down. It's the kind of investment that pays for itself quickly, and then gives a boost to your bottom line - every day you do business.

Commitment to innovation and safety

Rotary Lift continues to lead the industry in the manufacturing of lifts in multiple ISO9001- certified global facilities, with each lift designed to meet applicable ANSI standards. Rotary two-post lifts are third party tested by ETL and certified by ALI to meet or exceed strict ANSI standards.

Local Service and Support

With Rotary, you have the service and support you need. Our worldwide network of service companies, the industry's most extensive network of factory-trained professionals for specification, installation, parts and service are always standing by.



All from the brand you've trusted since 1925.

Rotary Lift.

EXCLUSIVE TWO-POST LIFT FEATURES

TRIO™ three-stage arms for asymmetrical and symmetrical lifts

increase overall arm sweep and minimum arm reach to precisely lift a variety of vehicles with uni-body construction, a wider vehicle treadwidth, or a short or long wheelbase.

SHOCKWAVE-equipped lifts are the fastest in the world.

Twice as fast as standard lifts increasing productivity and profits.

Three-stage arms on symmetrical lifts increase overall arm sweep and minimum arm reach versus two-stage arms. (Available on SP010, standard on SP012)

Rotary® power units are designed, tested and built by Rotary.

We don't use 3rd party power units which are for universal applications.

Multi position wheel spotting dishes provide accurate positioning of vehicles.

High-pressure, full stroke cylinders in each column provide maximum lifting force.

Multi-position column locks engage every 4" and are fully accessible for maintenance.

Multiple contact / adapter options. From three-position flip-up adapters, stackable adapters with thread-up adjustments and drive-over fixed pads, there is a perfect combination to choose from when spotting vehicles.

Conventional power configuration features a convenient column location and easy-to-use two-hand operation with a manual release locking system. Increase the speed of the lift with an optional 3-phase power unit.

Original "Double S" single piece column design maximizes column strength

Slider block bearings of Tivar® 1000 polyethylene are self-lubricating and maintenance free.

Arm restraints make positioning of arms easy. They engage when the lift is raised and automatically disengage when the lift is fully lowered.

Overhead cables and a clear floor design ensure proper equalization of the carriages, while providing an unobstructed floor.

Overhead padded switch bar prevents damaging a vehicle by raising it too high.

Adjustable height options column extensions gives you the flexibility to lift and service taller vehicles.

VEHICLE CONTACT CONFIGURATIONS

FA three-position flip-up adapters

with built-in height adapters are great for quick positioning on a variety of pick-up points. Multiple auxiliary adapters are available.



RA round polymer adapters come standard with asymmetric **RA models** that thread-up or have optional stackable inserts. No metal to metal contact.



Polymer TA truck adapters that thread-up or have optional stackable inserts come standard with 10,000 - 12,000 lbs. capacity **TA models**. No metal to metal contact.



Fixed moveable pad contact lifts are optimal for quick vehicle spotting. The 7,000 lbs. capacity **MP** model lift is perfect for quick-lube bays.



Stackable adapter extensions are specifically designed to provide additional lifting height when vehicles require additional clearance or use on front or rear to level vehicle on lift. Standard on 10,000 and 12,000 lbs. capacity **TA** lifts.



Stackable adapters with thread-up adjustment

come standard on 16,000 and 20,000 lbs. capacity lifts.



COLUMN ORIENTATION OPTIONS



Model shown: SPOA10N800BL
10,000 lbs. capacity asymmetric lift
Shown with optional accessories

True Asymmetrical Lifts 7,000 to 10,000 lbs. capacities

Columns are rotated 30° allowing maximum door opening on passenger cars for improved access to vehicle interior.

- Places the approximate center of gravity of the vehicle in line with the optimum load capability of the column

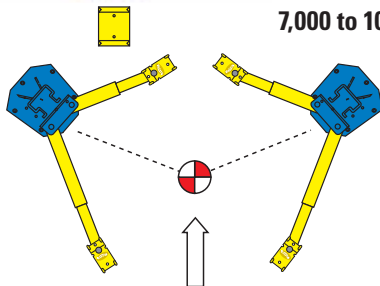

Asymmetrical column orientation



Model shown: SP012N7T5BL
12,000 lbs. capacity symmetric lift

True Symmetrical Lifts 7,700 to 20,000 lbs. capacities

Lift columns are not rotated providing more width between columns to accommodate larger vehicles and improve vehicle access - allows max door opening on trucks and vans for access to vehicle interior.

- Vehicle load is centered between the columns to maximize lifting capacity

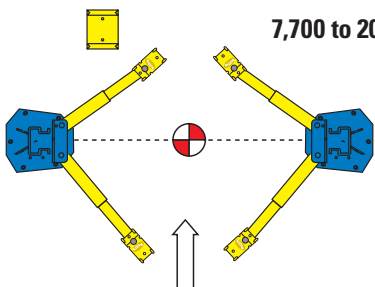

Symmetrical column orientation

MAKE YOUR TWO POST LIFT 2X FASTER! SUPERCHARGE YOUR LIFT WITH SHOCKWAVE™



25 second rise time!
19 second descent!*



Model shown: SPOA10U8G5RD
10,000 lbs. capacity SHOCKWAVE equipped lift

The Industry Standard JUST GOT FASTER!



Shockwave's patent pending DC power system gives you lower cost and more reliable operation while using two standard Group 24 batteries.** Shockwave's built in battery charger uses 110v power, eliminating the need for expensive 220v wiring resulting in an installation savings of 80% or more! Available on 7,000 to 20,000 capacity 2-post lifts.

*Actual rise and descent times may vary depending on weight of the vehicle. **Batteries not included

SHOCKWAVE-EQUIPPED LIFTS FEATURE



2X faster rise and descent



Spotline™ motion activated laser helps spot vehicles the first time



DC power reduces operating cost



More productivity makes happier technicians

- Accelerate your productivity immediately!
- Increase your number of service orders per bay!
- Added productivity equals EXTRA PROFIT!

Rotary DESIGN ADVANTAGE

SHOCKWAVE Two-Post

PRODUCTIVITY & PERFORMANCE

- PATENT PENDING DC POWER - PROVIDES 2X FASTER SPEED
- SPOTLINE™ LASER VEHICLE SPOTTING
- HIGHER RISE
- INEXPENSIVE DAILY OPERATION
- THIRD-PARTY ETL GOLD CERTIFIED



Model shown: SPOA10N8G5BL
Shown with optional accessories
and additional equipment

SPOA10TRIO™

Two-Post Lift Series

10,000 LBS. CAPACITY LIFTS

INNOVATING...NOT IMITATING!

The world's best selling asymmetrical lift is available to service a broader range of vehicles - with one innovative arm design!

Versatility

TRIO™ Series asymmetric lifts are three arm configurations in one low-profile arm design. With lifting capabilities of 10,000 lbs., Rotary engineers have created a **patented two-piece, three-stage asymmetrical arm** that accommodates a wider range of vehicles. Versatility in matching the right adapters on a single lift is a win for any service bay and adapters are now interchangeable with three vehicle contact options. Technicians can choose the best adapter set for each vehicle to be serviced all on the same arm.

Vehicle Spotting Speed

TRIO™ arms allow for quick positioning of the adapter to the vehicle pickup point without moving heavy two or three stage inner arms.

The patented, integrated "third stage" adjustment easily and quickly slides the adapter to a pinpoint vehicle contact location saving technicians even greater set-up time. Discover the TRIO™ arm's competitive, industry exclusive advantage that only Rotary offers!



THIRD STAGE
adapter slider
adjustment range

Greater productivity equals higher profits per bay, every day!

Lift shown with **three-stage TRIO™ arms** with **Round (RA) Adapters** Model #SPOA10-TRIO-RA / 10,000 lbs. capacity

SPOA10TRIO™ THREE STAGES OF FLEXIBILITY IN A TWO-PIECE ARM

STAGE ONE

Front and rear TRIO arms at full retraction.



1st STAGE REACH

Stage one adapter micro adjustment range at full retraction.

Shown with RA adapter



STAGE TWO

Front and rear TRIO arms at full arm extension.



2nd STAGE REACH

Single inner arm shown at full retraction and full extension.

Shown with RA adapter



STAGE THREE

Front and rear TRIO arms at full arm extension with adapter adjustment range.

No heavy inner arms to move for positioning.



3rd STAGE REACH

Patented multi-position adapter slider*

Integrated "third stage" adapter adjustment easily slides to a pinpoint location.



* 3rd stage RA has 8.34" (212mm) of adjustability / 3rd stage FA has 6.93" (176mm) of adjustability - EXAMPLE SHOWN ON TRIO REAR ARM WITH RA ADAPTER

VERSATILE TRIO™ ARM ADAPTERS ARE INTERCHANGEABLE WITH THREE OPTIONS
 Technicians can choose the best optional adapter set for their lifting needs!*

Three-Position Flip-Up Adapters (FA)

LIFT MODEL #SPOA10-FA-TRIO



Multiple auxiliary adapters are available.

Perfect adapter for quick positioning on a variety of pick-up points.

KIT #T100274
 Includes four (4) adapters

Round Adapters (RA)

LIFT MODEL #SPOA10-RA-TRIO



#FJ6219

Set of four (4) FJ6219 polymer pad round adapters. Adapters thread-up to allow protection of the vehicle underbody components or undercoating for no metal to metal contact. Also available for use with stackable inserts.

SET OF 4 KIT #T100272

Truck Adapters (TA)

LIFT MODEL #SPOA10-TA-TRIO



#T110564
 For 10,000 lbs. (4536kg) capacity lifts - includes four (4) adapters.

Auxiliary adjustable thread-up adapter with rubber pads allow for protection of underbody vehicle components or undercoating. Required use when lifting trucks and other frame vehicles. For 10,000 lbs. (4536kg) capacity lifts

SET OF 4 KIT #T100273

Stackable inserts come standard on 10,000 lbs. and 12,000 lbs. capacity TA models



*NEW SPOA10 TRIO LIFTS COME STANDARD WITH YOUR CHOICE OF FA, RA OR TA ADAPTERS. EACH ADDITIONAL ADAPTER SET IS SOLD SEPARATELY.

True Asymmetrical Lifts are rotated 30° allowing maximum door opening for improved access to vehicle interior.



Model shown: SPOA10N8G5BL
 Shown with optional accessories and additional equipment



TRIO™ ARM SWEEP vs CONVENTIONAL 2-STAGE ARMS

GREATER REACH AND ENHANCED RETRACTION

Shown with three-position FA adapters

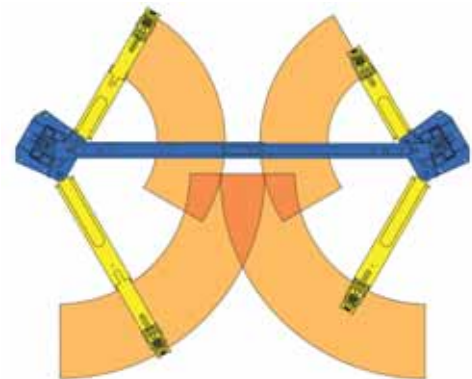

TRIO™ ARMS with FLIP-UP ADAPTERS

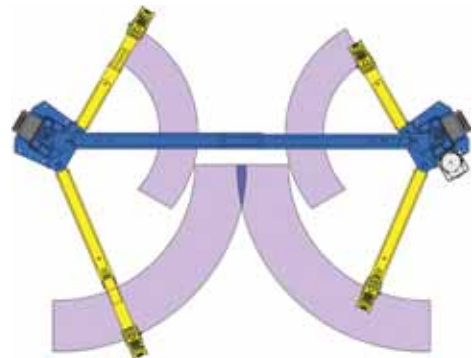

CONVENTIONAL 2-STAGE ARMS with FLIP-UP ADAPTERS



Two-Post TRIO™
 PRODUCTIVITY & PERFORMANCE

1. PATENTED, TWO-PIECE, THREE-STAGE ARM DESIGN
2. GREATER REACH WITH LOW PROFILE ARMS
3. AVAILABLE WITH SHOCKWAVE
 - DC POWER PROVIDES 2X FASTER SPEED
4. ADAPTERS ARE INTERCHANGEABLE ON ONE ARM
5. THIRD-PARTY ETL GOLD CERTIFIED

LIGHT DUTY TWO-POST ASYMMETRIC LIFTS

SPOA7 7,000 LBS. CAPACITY QUICK SERVICE PAD LIFT

Get The Quick Jobs In And Out With This Quick Service Pad Lift!

- Low profile drive-over lift allows vehicles to be spotted quickly and accurately with easy to adjust pad
- Original "Double S" column design
- ALI Gold Certified

Improve vehicle reach with adjustable drive-over pads

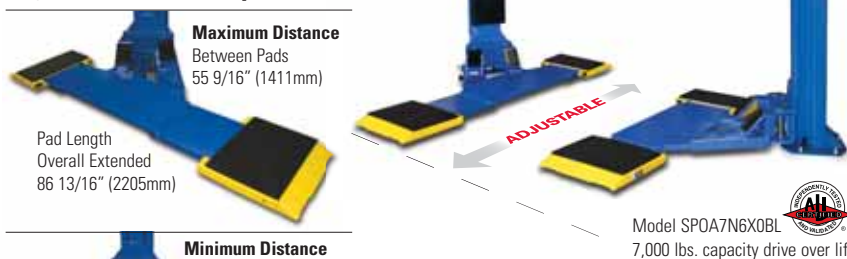

Maximum Distance
Between Pads
55 9/16" (1411mm)

Pad Length
Overall Extended
86 13/16" (2205mm)

Minimum Distance
Between Pads
39 9/16" (1004mm)

Pad Length
Overall Retracted
70 13/16" (1799mm)

Hinged approach ramps

Model SPOA7N6X0BL
7,000 lbs. capacity drive over lift



Four (4) each 1.5" and 3" spacer blocks are included with lift

Rubber spacer blocks provide additional clearance when needed.

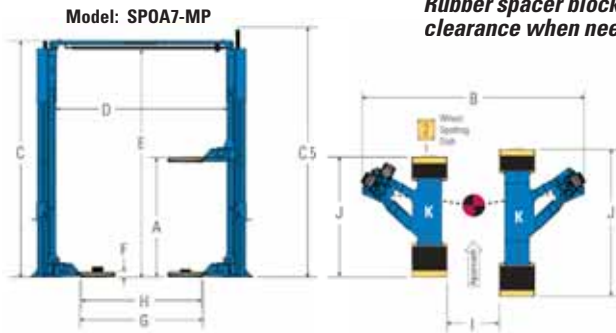

Model: SPOA7-MP

* Rise is measured from floor to top of pad at full cylinder stroke. Rise dimensions increase by 3" with extended rise options
NO PAD: 74"
1-1/2" PAD: 75 1/2"
3" PAD: 77"



Available with **SHOCKWAVE™**



Model:	SPOA7-MP
WITH SHOCKWAVE	SPOA7-MPSW
Lifting Capacity	7,000 lbs. (3157kg)
Lifting Capacity (per platform)	3,500 lbs. (1588kg)
A. Rise*	74"-77" (1880-1956mm)
B. Width Overall**	11' 5 3/8" (3489mm)
C. Floor to Top of Overhead	Standard 11' 8 1/2" (3569mm)
	EH1 12' 8 1/2" (3874mm)
	EH2 13' 8 1/2" (4178mm)
C.5 Cylinder at Full Rise	Standard 11' 10 3/4" (3625mm)
WITH SHOCKWAVE	12' 4 3/4" (3778mm)
D. Width Between Columns	107" 1/4" (2724mm)
E. Floor to Overhead Switch	11' 2 3/4" (3423mm)
F. Drive Over Clearance	2 5/8" (67mm)
G. Drive-Thru Clearance	79" (2007mm)
H. Outside of Pad to Outside of Pad	78 1/2" (1994mm)
I. Inside of Pad to Inside of Pad	37 1/8" (968mm)
J. Pad Length Overall Retracted	70 13/16" (1799mm)
Pad Length Overall Extended	86 13/16" (2205mm)
K. Minimum Distance Between Pads	39 9/16" (1004mm)
Maximum Distance Between Pads	55 9/16" (1411mm)
Motor Performance	2hp
WITH SHOCKWAVE	5hp
Voltage Single Phase***	208/230v
WITH SHOCKWAVE	110v
Time of Rise	45 seconds
WITH SHOCKWAVE	25 seconds
Ceiling Height Required:	12' (3658mm)
WITH SHOCKWAVE	12' 6" (3810mm)
Min. Bay Size	12' x 24' (3658 x 7315mm)

** Overall heights and widths reflect standard settings. Alternate settings may be available - consult factory for details.
 ***Optional 3-phase electrical available

AT07 7,700 LBS. CAPACITY SPACE SAVING TWO POST LIFT

Asymmetric two-post lift designed for maximum drive-thru clearance with minimal footprint.

- Over 14" narrower than standard two post lift - fits in a 11' wide bay
- Can be entered from either side - power unit mounts on either side of lift
- ALI Gold Certified

30° rotated column design of the posts and supporting three-stage front arms and two-stage rear arms provides a spacious pick-up area - allows for greater open door clearance.

LIFT AVAILABLE IN BLUE ONLY

Lift shown with **three-stage front arms, two-stage rear arms** with **Round (RA) Adapters**
Stackable adapters and storage rack included



Asymmetric design allows for open door clearance



Model: AT07N100BL
7,700 lbs. capacity asymmetric lift



Available with SHOCKWAVE™



SPOA10

10,000 LBS. CAPACITY

THE INDUSTRY STANDARD

For over 30 years, Rotary has engineered asymmetrical lifts with the quality and attention to detail that can't be found anywhere else.

- True asymmetrical rotated column design
- Standard 2-stage arms with flip-up FA adapters
- Original "Double S" column design
- Adjustable lift height options to service taller vehicles
- ALI Gold Certified

Lift shown with **three-position Flip-Up (FA) Adapters** with built-in height adapters on conventional 2-stage arms

SPOA10 / 10,000 lbs. capacity



Model shown: SPOA10N700BL
Shown with optional accessories and additional equipment

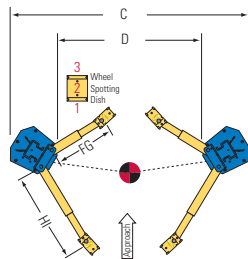
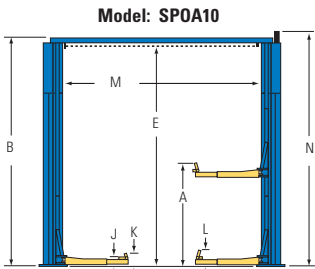

* Rise measures lowest or highest position of the supplied adapters from floor to full cylinder stroke.

** Overall heights and widths reflect standard settings. Alternate settings may be available, refer to Installation Instruction Manual or consult factory for details.

***Optional 3-phase electrical available.

Model	SPOA10
WITH SHOCKWAVE	SPOA10-SW
Capacity	10,000 lbs. (4536kg)
Rise*	72 3/4" - 78 1/4" (1848 - 1987mm)
WITH SHOCKWAVE	75 3/4" - 81 1/4" (1924 - 2064mm)
Height Overall	11' 8 1/2" (3569mm)
Width Overall** (outside of base plate)	11' 5 3/8" (3489mm)
Drive-Thru Clearance	95 1/4" (2416mm)
Floor To Overhead Switch	11' 2 3/4" (3423mm)
Reach (front arm min.)	24" (610mm)
Reach (front arm max.)	40 3/4" (1036mm)
Reach (rear arm min.)	40 1/4" (1019mm)
Reach (rear arm max.)	61" (1548mm)
Min. Adapter Height	4 3/4" (121mm)
Max. Adapter Height	N/A
Low Step Height	7" (178mm)
High Step Height	10 1/4" (260mm)
Inside Columns	107 1/4" (2727mm)
Cylinder Height	11' 10 1/2" (3619mm)
WITH SHOCKWAVE	12' 4 1/2" (3772mm)
Motor / Voltage 1Ø***	2 HP / 208v-230v
WITH SHOCKWAVE	5 HP / 110v
Time of Full Rise / Descent	45 / 40 seconds
WITH SHOCKWAVE	25 / 19 seconds
Ceiling Height Required:	12' (3658mm)
WITH SHOCKWAVE	12' 6" (3810mm)
Min. Bay Size	12' x 24' (3658 x 7315mm)

Model: AT07

Capacity	7700 lbs (3493kg)
A. Rise*	73 7/8" (1877mm)
B. Height Overall	11' 10 7/8" (3627mm)
C. Width Overall	10' 2 7/8" (3120mm)
D. Drive-Thru Clearance	92" (2336mm)
E. Floor To Overhead Switch	134 3/8" (3414mm)
F. Reach (front arm min.)	21 1/8" (360mm)
G. Reach (front arm max.)	43 1/2" (1105mm)
H. Reach (rear arm min.)	32 15/16" (837mm)
I. Reach (rear arm max.)	58" (1473mm)

J. Min. Adapter Height	3 5/8" (92mm)
K. Max Adapter Height	5 7/8" (149mm)
L. Inside Columns	100 3/4" (2560mm)
Motor	2HP
Voltage**	1PH/60HZ/208-230V
Time of Full Rise	45 seconds
Ceiling Height Required	12' (3660mm)
Stackable adapters (4)	3 1/2" (90mm)
Stackable adapters (4)	5 1/8" (130mm)
Min bay size	11' x 24' (3353 x 7315mm)

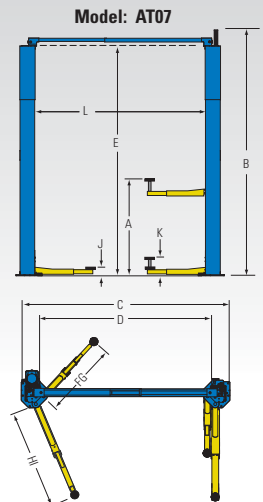

* Rise measures highest position of the supplied adapters from floor to full cylinder stroke

** Optional 3-phase electric available

AT07 is available in blue only.

RAL5005

Standard color of SPOA7 and SPOA10 lifts are blue and red unless otherwise noted. Gray and black are available at no additional charge.

AT07 lifts are available in blue only. Additional colors are available, consult your Rotary® representative for details.

RAL5005 RAL3002 RAL7040 RAL9005

ASYMMETRIC LIFTS *PERFECT DESIGN FOR CARS and LIGHT TRUCKS*

SPOA10-SWTRIO™

10,000 LBS. CAPACITY

**SHOCKWAVE-EQUIPPED TWO-POST LIFTS;
STANDARD WITH SPEED, CHOICE & R.O.I.**

These are the fastest lifts in the world specifically designed for service bays where speed is essential. Achieve your goals of greater technician productivity and higher profits with exclusive lift technology available only from Rotary.

- Low profile TRIO™ 2-piece, three-stage arms
- DC Power with continuous onboard 110v charger
- Spotline™ motion activated laser
- Original "Double S" column design
- ALI Gold Certified



2X faster rise and descent

**25 second rise time!
19 second descent!***



Model shown: SPOA10U8G5RD
SHOCKWAVE equipped asymmetric lift

Lift shown with **three-stage TRIO™ arms with Round (RA) Adapters**



Model #SPOA10-TRIO-RASW / 10,000 lbs. capacity

*Actual rise and descent times vary depending on weight of vehicle.

CUSTOMIZE WITH YOUR SHOCKWAVE-EQUIPPED LIFT WITH TRIO™ ARMS or DRIVE OVER PAD LIFT.

- **TRIO™ arms with Flip-Up (FA) Adapters**
Model #SPOA10-TRIO-FASW / 10,000 lbs. capacity
- **TRIO™ arms with (TA) Truck Adapters**
Model #SPOA10-TRIO-TASW / 10,000 lbs. capacity
- **Drive over movable pads with multi-positionable spacer blocks**
Model #SPOA7-MPSW / 7,000 lbs. capacity

SUPERSTRUCTURE SHOWN:

#SPOA7-MPSW / 7,000 lbs. capacity



Ultra low profile **movable pad** slides easily into place for lifting unibody vehicles

SPOA10TRIO™ 10,000 LBS. CAPACITY

THE INDUSTRY STANDARD JUST GOT MORE VERSATILE!

The industry's original and best selling asymmetrical lift is updated for even greater productivity.

- Low profile TRIO™ 2-piece, three-stage arms
- Customize with three easy-to-change adapter options
- True asymmetrical rotated column design
- Original "Double S" column design
- Adjustable lift height options to service taller vehicles
- ALI Gold Certified

ALSO AVAILABLE WITH

- **Three-stage TRIO™ arms with Flip-Up (FA) Adapters**
Model #SPOA10-TRIO-FA / 10,000 lbs. capacity
- **Three-stage TRIO™ arms with (TA) Truck Adapters**
Model #SPOA10-TRIO-TA / 10,000 lbs. capacity

Lift shown with **three-stage TRIO™ arms with Round (RA) Adapters**



Model #SPOA10-TRIO-RA
10,000 lbs. capacity



Model shown: SPOA10N8G5BL
Shown with optional accessories and additional equipment

LIFT SPECIFICATIONS / 7,000 lbs. to 10,000 lbs. CAPACITIES

Available with
SHOCKWAVE™



Model	SPOA10-TRIO-FA TRIO 3-STAGE Arms Flip Up Adapters	SPOA10-TRIO-TA TRIO 3-STAGE Arms Truck Adapters	SPOA10-TRIO-RA TRIO 3-STAGE Arms Round Adapters
SHOCKWAVE Models	SPOA10-TRIO-FASW SHOCKWAVE LIFT	SPOA10-TRIO-TASW SHOCKWAVE LIFT	SPOA10-TRIO-RASW SHOCKWAVE LIFT
Capacity	10,000 lbs. (4536kg)	10,000 lbs. (4536kg)	10,000 lbs. (4536kg)
A. Rise*	72 1/2" - 78" (1841 - 1981mm)	72" - 82 1/2" (1829 - 2095mm)	71 7/8" - 73 1/8" (1826 - 1857mm)
WITH SHOCKWAVE	75 1/2" - 81" (1917 - 2057mm)	75" - 85 1/2" (1905 - 2172mm)	74 7/8" - 76 1/8" (1902 - 1933mm)
B. Height Overall †	11' 8 1/2" (3569mm)	11' 8 1/2" (3569mm)	11' 8 1/2" (3569mm)
C. Width Overall** (outside of base plate)	11' 5 3/8" (3489mm)	11' 5 3/8" (3489mm)	11' 5 3/8" (3489mm)
D. Drive-Thru Clearance	95 1/4" (2416mm)	95 1/4" (2416mm)	95 1/4" (2416mm)
E. Floor To Overhead Switch	11' 2 3/4" (3423mm)	11' 2 3/4" (3423mm)	11' 2 3/4" (3423mm)
F. Reach (front arm min.)	21 3/4" (552mm)	20 1/2" (521mm)	20 1/2" (521mm)
G. Reach (front arm max.)	43 1/2" (1105mm)	40 3/4" (1035mm)	40 3/4" (1035mm)
H. Reach (rear arm min.)	37" (940mm)	34 1/2" (876mm)	34 1/2" (876mm)
I. Reach (rear arm max.)	61" (1548mm)	58 1/4" (1479mm)	58 1/4" (1479mm)
J. Min. Adapter Height	4 3/4" (121mm)	4 1/8" (105mm)	3 31/32" (101mm)
Max. Adapter Height	N/A	5 3/8" (136mm)	5 1/4" (133mm)
K. Low Step Height	6 7/8" (175mm)	N/A	N/A
L. High Step Height	10 3/8" (263mm)	N/A	N/A
M. Inside Columns	107 1/4" (2727mm)	107 1/4" (2727mm)	107 1/4" (2727mm)
N. Cylinder Height	11' 10 1/2" (3619mm)	11' 10 1/2" (3619mm)	11' 10 1/2" (3619mm)
WITH SHOCKWAVE	12' 4 1/2" (3772mm)	12' 4 1/2" (3772mm)	12' 4 1/2" (3772mm)
Motor / Voltage 1Ø***	2 HP / 208v-230v	2 HP / 208v-230v	2 HP / 208v-230v
WITH SHOCKWAVE	5 HP / 110v	5 HP / 110v	5 HP / 110v
Time of Full Rise / Descent	45 / 40 seconds	45 / 40 seconds	45 / 40 seconds
WITH SHOCKWAVE	25 / 19 seconds	25 / 19 seconds	25 / 19 seconds
Ceiling Height Required:	12' (3658mm)	12' (3658mm)	12' (3658mm)
WITH SHOCKWAVE	12' 6" (3810mm)	12' 6" (3810mm)	12' 6" (3810mm)
Min. Bay Size	12' x 24' (3658 x 7315mm)	12' x 24' (3658 x 7315mm)	12' x 24' (3658 x 7315mm)

SPOA7-MPSW Drive-Over Moveable Pads SHOCKWAVE LIFT	
Capacity	7,000 lbs. (3157kg)
Per Platform	3,500 lbs. (1588kg)
A. Rise*	74" - 77" (1880-1956mm)
B. Width Overall**	11' 5 3/8" (3489mm)
C. Floor to Top of Overhead	11' 8 1/2" (3569mm)
C.5 Cylinder at Full Rise	12' 4 3/4" (3778mm)
D. Width Between Columns	107" 1/4" (2724mm)
E. Floor to Overhead Switch	11' 2 3/4" (3423mm)
F. Drive Over Clearance	2 5/8" (67mm)
G. Drive-Thru Clearance	79" (2007mm)
H. Outside of Pad to Outside of Pad	78 1/2" (1994mm)
I. Inside of Pad to Inside of Pad	37 1/8" (968mm)
J. Overall Pad Length	
Retracted	70 13/16" (1799mm)
Extended	86 13/16" (2205mm)
K. Min. / Max. Distance Between Pads	39 9/16" (1004mm) 55 9/16" (1411mm)
Min. Adapter Height	2 5/8" (67mm)
Motor / Voltage***	5hp / 110v
Time of Full Rise / Descent	25 / 19 seconds
Ceiling Height Required	12' 6" (3810mm)
Min. Bay Size	12' x 24' (3658 x 7315mm)

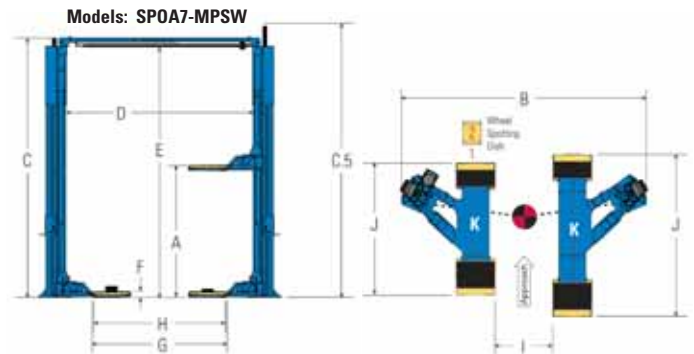
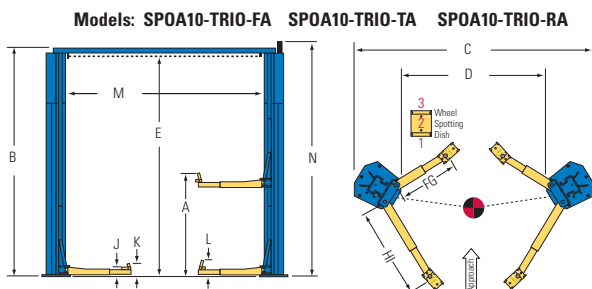

* Rise measures lowest or highest position of the supplied adapters from floor to full cylinder stroke.
 ** Overall heights and widths reflect standard settings. Alternate settings may be available, refer to Installation Instruction Manual or consult factory for details.
 *** Optional 3-phase electrical available.
 † Optional higher rise and extended height options available for SPOA10 models - consult factory for details.

* Rise is measured to top of pad / Rise dimensions increase by 3" with extended rise options:
 NO PAD: 74" 1 1/2" PAD: 75 1/2" 3" PAD: 77"
 ** Overall heights and widths reflect standard settings. *** Optional 3-phase electric available

SYMMETRIC LIFTS *WIDER DRIVE THRU FOR TRUCKS AND VANS*



SPO10 10,000 LBS. CAPACITY

THE PROVEN STANDARD

Trust the industry standard symmetrical 10,000 lb. lift. Why look anywhere else?

- Customize with your choice of arms and adapters
- Original "Double S" column design
- Available with conventional 3-stage arms
- Available in extended height configurations
- ALI Gold Certified



Available with SHOCKWAVE™
SHOCKWAVE-Equipped SPO10-SW
Minimum Required Ceiling Height: 12' 6"

Lift shown with conventional three-position (FA) Flip-Up Adapters with built-in height adapters on 2-stage arms

Model #SPO10
10,000 lbs. capacity



ALSO AVAILABLE WITH

- **Three-stage arms with RA Adapters**
Model #SPO10-RA / 10,000 lbs. capacity
- **Three-stage arms with Truck Adapters**
Model #SPO10-TA / 10,000 lbs. capacity



Model shown: SPO10N707RD extended height lift
Shown with optional accessories and additional equipment

SPO12 12,000 LBS. CAPACITY

THREE STAGE ARMS for GREATER REACH

The Rotary SPO12 is the choice for medium-duty lifting and quality in 12,000 lb. lifts.

- Front & rear three-stage arms are standard
- Adjustable truck adapters with stackable inserts adds reach
- Low ceiling and extended height models available
- Original "Double S" column design
- ALI Gold Certified

Available with SHOCKWAVE™



EH3 EXTENDED HEIGHT MODEL AVAILABLE

ADDS 3' FOR EURO-STYLE CARGO VANS



Standard with three-stage FRONT arms and polymer Truck Adapters primarily used on framed vehicles. Adjustable adapters thread-up and come with stackable inserts and storage rack

Model #SPO12-TA
12,000 lbs. capacity



Model: SPO12U7T8RD / SHOCKWAVE lift shown with optional accessories and additional equipment



Model shown: SPO12N7T5BL
Shown with optional accessories and additional equipment

LIFT SPECIFICATIONS / 10,000 lbs. and 12,000 lbs. CAPACITIES

Available with
SHOCKWAVE™



SP010
Standard Arms
Flip Up Adapters



SP010-RA
Three-Stage Arms
Round Adapters



SP010-TA
Three-Stage Arms
Truck Adapters



SP012-TA
Three-Stage Arms
Truck Adapters

Model:	SP010	SP010-RA	SP010-TA	SP012-TA
SHOCKWAVE Models	SP010-SW SHOCKWAVE LIFT	SP010-RASW SHOCKWAVE LIFT	SP010-TASW SHOCKWAVE LIFT	SP012-SW SHOCKWAVE LIFT
A. Rise*	72 5/8" - 78 1/8" (1845 - 1984mm)	72 1/2" - 74 3/4" (1841 - 1898mm)	72 5/8" - 75 5/8" (1845 - 1921mm)	72 3/4" - 75 3/4" (1848 - 1924mm)
	WITH SHOCKWAVE	WITH SHOCKWAVE	WITH SHOCKWAVE	WITH SHOCKWAVE
B. Height Overall: Standard	11' 8 1/2" (3569mm)	11' 8 1/2" (3569mm)	11' 8 1/2" (3569mm)	STD. 13' 8" (4166mm)
EH1 - adds 3" of rise height	12' 8 1/2" (3873mm)	12' 8 1/2" (3873mm)	12' 8 1/2" (3873mm)	EH1 14' 8" (4470mm)
EH2 - adds 3" of rise height	13' 8 1/2" (4178mm)	13' 8 1/2" (4178mm)	13' 8 1/2" (4178mm)	EH2 15' 8" (4775mm)
EH4 - adds 3" of rise height	14' 8 1/2" (4483mm)	14' 8 1/2" (4483mm)	14' 8 1/2" (4483mm)	EH4 16' 8" (5080mm)
C. Width Overall** (outside of base plate)	11' 5 1/2" (3493mm)	11' 5 1/2" (3493mm)	11' 5 1/2" (3493mm)	11' 5 5/8" (3496mm)
D. Drive-Thru Clearance	102 1/2" (2603mm)	102 1/2" (2603mm)	102 1/2" (2603mm)	102 3/8" (2600mm)
E. Floor To Overhead Switch	11' 2 3/4" (3423mm)	11' 2 3/4" (3423mm)	11' 2 3/4" (3423mm)	13' 3 1/8" (4042mm)
F. Reach (front arm min.)	31" (787mm)	27 1/2" (699mm)	27 1/2" (699mm)	27 1/2" (699mm)
G. Reach (front arm max.)	54" (1372mm)	59" (1499mm)	59" (1499mm)	59" (1499mm)
H. Reach (rear arm min.)	31" (787mm)	27 1/2" (699mm)	27 1/2" (699mm)	27 1/2" (699mm)
I. Reach (rear arm max.)	54" (1372mm)	59" (1499mm)	59" (1499mm)	59" (1499mm)
J. Min. Adapter Height	4 5/8" (118mm)	4 1/2" (114mm)	4 5/8" (118mm)	4 3/4" (121mm)
Max. Adapter Height	N/A	6 3/4" (171mm)	7 5/8" (194mm)	7 3/4" (197mm)
K. Low Step Height	7" (178mm)	N/A	N/A	N/A
L. High Step Height	10 1/4" (260mm)	N/A	N/A	N/A
M. Inside Columns	114 1/2" (2908mm)	114 1/2" (2908mm)	114 1/2" (2908mm)	114 7/8" (2918mm)
N. Cylinder Height at full rise*	11' 10 3/4" (3626mm)	11' 10 3/4" (3626mm)	11' 10 3/4" (3626mm)	11' 10 3/4" (3626mm)
	WITH SHOCKWAVE	WITH SHOCKWAVE	WITH SHOCKWAVE	WITH SHOCKWAVE
Lifting Capacity	10,000 lbs. (4536kg)	10,000 lbs. (4536kg)	10,000 lbs. (4536kg)	12,000 lbs. (5443kg)
Motor / Voltage***	2 HP / 208v-230v	2 HP / 208v-230v	2 HP / 208v-230v	2 HP / 208v-230v
	WITH SHOCKWAVE	WITH SHOCKWAVE	WITH SHOCKWAVE	WITH SHOCKWAVE
Time of Full Rise	45 seconds	45 seconds	45 seconds	60 seconds
	WITH SHOCKWAVE	WITH SHOCKWAVE	WITH SHOCKWAVE	WITH SHOCKWAVE
Ceiling Height Required:				
Standard	12' (3658mm)	12' (3658mm)	12' (3658mm)	13' 9" (4191mm)
	WITH SHOCKWAVE	WITH SHOCKWAVE	WITH SHOCKWAVE	WITH SHOCKWAVE
EH1	12' 10" (3912mm)	12' 10" (3912mm)	12' 10" (3912mm)	EH1 14' 9" (4496mm)
EH2	13' 10" (4216mm)	13' 10" (4216mm)	13' 10" (4216mm)	EH2 15' 9" (4801mm)
EH3	14' 10" (4521mm)	14' 10" (4521mm)	14' 10" (4521mm)	EH4 16' 9" (5105mm)
Max Load (per arm)	2,500 lbs. (1134kg)	2,500 lbs. (1134kg)	2,500 lbs. (1134kg)	3,000 lbs. (1360kg)
Min. Bay Size	12' x 24' (3658 x 7315mm)	12' x 24' (3658 x 7315mm)	12' x 24' (3658 x 7315mm)	12' x 26' (3658 x 7925mm)

Models: SP010 SP010-RA SP010-TA SP012-TA

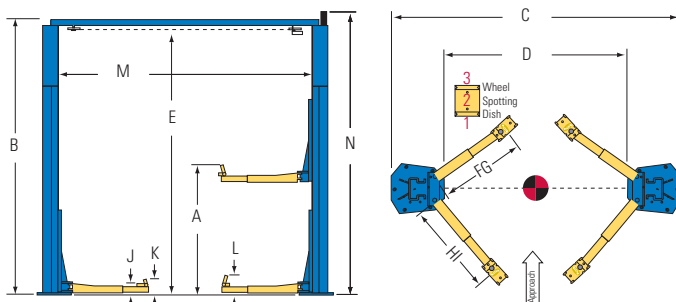

* Rise measures lowest or highest position of the supplied adapters from floor to full cylinder stroke.

** Overall heights and widths reflect standard settings. Alternate settings may be available, refer to Installation Instruction Manual or consult factory for details.

***Optional 3-phase electrical available.

Standard color of lifts are blue and red unless otherwise noted. Gray and black are available at no additional charge. Additional colors are available, consult your Rotary® representative for details.

	RAL5005		RAL3002
	RAL7040		RAL9005

SYMMETRIC LIFTS *WIDER DRIVE THRU FOR TRUCKS AND VANS*

NEW SUPER DUTY SYMMETRIC LIFTS WITH GREATER LIFTING CAPACITIES AND PATENTED TRIO™ ARMS!

SPO20-SW 20,000 LBS. CAPACITY

VERSATILE SUPER LIFT
The industry's standard 20,000 lbs. heavy-duty two post lift is now the world's fastest!



Model shown: SPO20U0T0RD
 20,000 lbs. capacity SHOCKWAVE-equipped lift

LOW CEILING MODEL AVAILABLE

PICK UP A GREATER VARIETY OF VEHICLES FASTER AND EASIER ALL ON ONE HEAVY DUTY 2-POST LIFT.*

Packed with industry leading features, Rotary's new SPO Series lifts combine high capacity, a low profile stance, wider options and extreme arm reach possibilities with patented lifting speed!

SHOP VERSATILITY

*From Class 1 to Class 5 vehicles, low profile TRIO™ arms maximize lifting capabilities as never before.**

Service your entire fleet on a single lift!

SPO16 / 20 LIFT FEATURES

NEW low profile TRIO™ 2-piece, three-stage arms with stackable thread up adapters make contact to the vehicle faster and easier than before.

Multiple lift height options:

Standard: 15' to 16' 6" / Low ceiling: 13' 6" to 14' 6"

Three column width options from 12' 11" to 13' 11"

- Air operated single point lock release
- Available with SHOCKWAVE™
- 20 second lowering time - at any lift load
- Rise height of over 80"
- Locking system engages every 4"
- Original "Double S" column design
- Four (4) 5" adapter extensions and two (2) 10" extensions for added lifting height and reach
- ALI Gold Certified

SPO16

16,000 LBS. CAPACITY

SERVICE FLEET LINES and MORE

Setting the mark for reliability and quality in heavy duty lifts.



Available with SHOCKWAVE™



Model shown: SPO160T0BL
 16,000 lbs. capacity 2-post lift

LOW CEILING MODEL AVAILABLE



SPO16 CARGO

16,000 LBS. CAPACITY

All the features and options of the high capacity SPO16 with an arm configuration designed to service longer van wheelbases.

Standard, heavy-duty 3-stage arms with a greater spotting range allowing techs to reach specific vehicle pickup points.



Maximum reach: 74 13/16"

Minimum reach: 36 13/16"

***NOTE:** Level bay floors provide the best underbody clearance needed to accommodate the broadest range of vehicles to spot and lift. Wide setting installations create the best tire clearance on shorter wheelbases. Vehicle axle weight MUST NOT EXCEED one half of total lift capability. Maximum arm load is 1/4 of lift rated capacity. SPO16/20 lifts are designed for most class 4 and 5 vehicles. Some vehicles within each class may exceed arm capacity but not the lift capacity. Please consult vehicle axle information and lift manual for more information.

LIFT SPECIFICATIONS / 16,000 lbs. to 20,000 lbs. CAPACITIES

SPO SERIES LIFTS FEATURE THREAD-UP ADAPTERS FOR EASY VEHICLE CONTACT

Adjustable adapters with clip-on rubber pads come standard with ultra-strong 10" (2 each) and 5" (4 each) stackable adapter extensions.



Minimum Adapter Height: 5 31/32" (152mm)



Maximum Adapter Height: 8 1/32" (203mm)



5" Low Step Height: 10 31/32" to 13 1/32" (278-344mm)



10" High Step Height: 15 31/32" to 18 1/32" (406-470mm)

CLIP ON ADAPTER PADS



Rubber padded adapter clips provide lifting option for spotting unibody passenger cars. Set of four (4) standard.



OPTIONAL ROUND ADAPTERS FOR UNIBODY VEHICLES



Round rubber adapters provide 3/8" lower profile for pinch weld lifting.

LIFTING CAPACITY:

11,000 lbs. (4989kg) / 2,750 lbs. per arm (1247kg)

#FJ71015-1KIT for SPO16 / #FJ71016-1KIT for SPO20

Available with SHOCKWAVE™



SPO16
TRIO 3-STAGE Arms
Truck Adapters

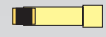

SPO20
TRIO 3-STAGE Arms
Truck Adapters

SHOCKWAVE Models	SPO16 -SW	SPO20 -SW
Lifting Capacity	16,000 lbs. (7257kg)	20,000 lbs. (9072kg)
Max. Load (per arm)	4,000 lbs. (1814kg)	5,000 lbs. (2268kg)
Rise*		
A. Min.Truck Adapter Height	77 31/32" (1979mm)	77 31/32" (1979mm)
Max.Truck Adapter Height	80 1/32" (2035mm)	80 1/32" (2035mm)
Height Overall:		
B. Standard Adjustments	15' to 16' 6" (4572-5029mm)	15' to 16' 6" (4572-5029mm)
Low Ceiling (LC)	13' 6" to 14' 6" (4115-4420mm)	13' 6" to 14' 6" (4115-4420mm)
Width Overall (outside to outside of base plates)		
C. Narrow	12' 11" (3937mm)	12' 11" (3937mm)
Standard	13' 5" (4089mm)	13' 5" (4089mm)
Wide	13' 11" (4242mm)	13' 11" (4242mm)
Wide width setting provides greatest tire clearance for shorter wheelbases		
Narrow Drive-Thru Clearance	105 11/32" (2677mm)	105 11/32" (2677mm)
D. Standard Drive-Thru Clearance	111 11/32" (2829mm)	111 11/32" (2829mm)
Wide Drive-Thru Clearance	117 11/32" (2981mm)	117 11/32" (2981mm)
E. Floor To Overhead Switch	15' 10 13/16" (4851mm)	15' 10 13/16" (4851mm)
F. Reach / Front Arm Min./Max.	34 11/16" (881mm) / 64" (1626mm)	34 11/16" (881mm) / 64" (1626mm)
G. Reach / Rear Arm Min./Max.	34 11/16" (881mm) / 64" (1626mm)	34 11/16" (881mm) / 64" (1626mm)
H. Min./Max. Truck Adapter Height	5 31/32" to 8 1/32" (152-203mm)	5 31/32" to 8 1/32" (152-203mm)
I. Min./Max. Low Step Height	10 31/32" to 13 1/32" (278-344mm)	10 31/32" to 13 1/32" (278-344mm)
J. Min./Max. High Step Height	15 31/32" to 18 1/32" (406-470mm)	15 31/32" to 18 1/32" (406-470mm)
Inside Columns		
K. Narrow	120 15/32" (3061mm)	120 15/32" (3061mm)
Standard	126 15/32" (3213mm)	126 15/32" (3213mm)
Wide	132 15/32" (3366mm)	132 15/32" (3366mm)
Motor / Voltage**	4 HP / 208v-230v	4 HP / 208v-230v
With SHOCKWAVE	5 HP / 110v	5 HP / 110v
Time of Full Rise	81 seconds at full capacity	81 seconds at full capacity
With SHOCKWAVE***	60 seconds at full capacity 36 seconds at half capacity	60 seconds at full capacity 36 seconds at half capacity
Time of Descent	20 seconds for all vehicle weights	
Ceiling Height Required:		
Standard	15' 2" to 16' 8" (4576-5080mm)	15' 2" to 16' 8" (4576-5080mm)
Low Ceiling (LC)	13' 8" to 14' 8" (4166-4470mm)	13' 8" to 14' 8" (4166-4470mm)
Min. Bay Size	15' x 30' (4572 x 9144mm)	15' x 30' (4572 x 9144mm)
Total Product Weight	3,500 lbs.	3,500 lbs.

Models: SPO16 / SPO20

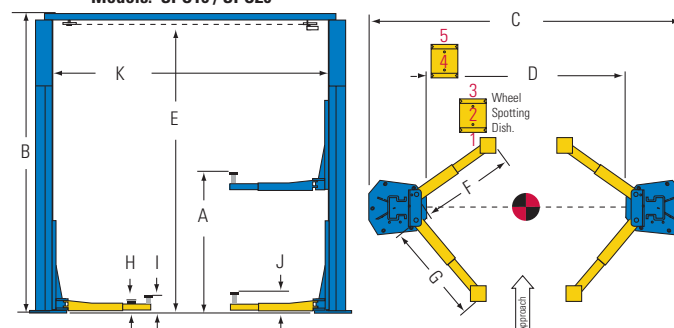

* Rise is measured from floor to adapter in lowest and highest position

** Optional DC SHOCKWAVE battery power available

*** Actual rise times may vary depending on weight of the vehicle

Standard color of lifts are blue and red unless otherwise noted. Gray and black are available at no additional charge. Additional colors are available, consult your Rotary® representative for details.

RAL5005 RAL3002 RAL7040 RAL9005



OPTIONAL LIFT ACCESSORIES

Increase bay productivity with these two-post lift accessories

FA Flip-Up Adapter for 3-Stage TRIO™ Arms

Standard three-position flip-up adapter is perfect for quick positioning on a variety of pick-up points.



KIT #T100274 for 10,000 lbs. (4536kg) capacity lifts

RA Adapter for 3-Stage TRIO™ Arms

KIT#T100272 Set of four (4) FJ6219 polymer pad round adapters. 10,000 lbs. (4536kg) capacity adapters thread-up to allow protection of the vehicle underbody components or undercoating for no metal to metal contact. For use when lifting uni-body construction vehicles. Also available for use with stackable inserts.



#FJ6219

RA Adapter for Conventional 3-Stage Arms

Set of four (4) FJ6202 polymer pad round adapters. **KIT #FJ6225** for 10,000 lbs. (4536kg) capacity lifts

TA Thread-Up Adapter for 3-Stage TRIO™ Arms

Auxiliary adjustable thread-up truck adapter adapter with rubber pads allow for protection of underbody vehicle components or undercoating. For raising certain vans or pickups. Also available for use with stackable inserts.



#T110564

KIT #T100273

includes (4) T110564 adapters Required use when lifting trucks and other frame vehicles. For 10,000 lbs. (4536kg) capacity lifts

TA Thread-Up for Conventional 3-Stage Arms

Auxiliary adjustable thread-up adapter with rubber pads. **KIT #FJ6197** includes (4) FJ6214 adapters for 10,000 lbs. (4536kg) capacity lifts

Adapter Extensions

Provides additional lifting height when vehicles require additional clearance or use on front or rear to level vehicle on lift. Includes four 3 1/2" (89mm) and four 5" (127mm) adapter extensions, mounting rack and hardware.

Adapter kit #T100271 fits TRIO models SPOA10 RA / TA

Adapter kit #FJ7880BK fits models SPO10 RA / TA and SPO12TA



Adapter and Mounting Rack

Required for raising minivans with running boards. Includes four adapters, mounting rack and hardware.

- Adjustable range provides 4 7/8" (124mm) to 6 3/4" (171mm) additional height
- Capacity 1,750 lbs. (794k) per adapter
- Rubber contact surface protects undercoated surfaces



#FJ6137BK

Auxiliary Adapters

Auxiliary adapters for use when raising certain vans or pickups. Includes four adapters, mounting rack and hardware.

- 2,500 lbs. (1134kg) capacity per adapter
- Adds 14 3/8" to 17 3/8" of additional overall adapter height (365 - 441mm)



#FJ6115BK

Adds 9 3/8" (238mm) of height - includes (4) 14 3/8" / 365mm adapters

#FJ6212KITYL - shorter version

Adds 7 3/8" (187mm) of height - includes 4 adapters

#FJ6195YL

Adds 12 3/8" (314mm) of height - includes 2 adapters

Extended Height Adapter

Required to lift 1988 or newer General Motors® GMT400 pickup trucks. Includes four adapters, mounting rack and hardware.

- Capacity 2,500 lbs. (1134kg) maximum per adapter
- Maximum overall height: 14" (356mm)



#FJ6133BK

Polymer Pad Adapter Kits

Polymer pad adapters for use with new car undercoating. Includes four adapters, mounting rack and hardware.

- 2,500 lbs. (1134kg) capacity per adapter
- Rubber contact surface protects undercoated surfaces



#FJ6190YL

(Adds 1" / 25mm)

#FJ6139BK

(Adds 2 1/2" / 63mm)

#FJ6138BK (Adds 1/2" / 12mm)

Adapters and Organizer Rack

Accommodate more vehicles quickly and easily with more adapters plus keep them organized.

- Four FJ696, four FJ697 and four FJ698 adapters
- Two piece column or wall-mounted adapter organizer rack (FJ6108)

Also available in different configurations.

CONSULT FACTORY FOR OPTIONS



#FJ6100BK

Air / Utility Box

Mounts easily on any column and provides quick access to utilities

- Two 110v electric outlets and air connection
- The filter/regulator/lubricator helps extend the life of your air tools

#FA5911BK



Tool Holder

To keep tools handy for the technician, this patented tool holder keeps air guns, torque sticks, and other tools within easy reach. This accessory mounts easily in holes already drilled and tapped in the two-post column.

#FA5191EBK



Extended Height Kits

Raise the overhead clearance on 10,000 and 12,000 lbs. capacity two-post lifts to service more vehicles at a comfortable working height. Kit includes column extensions and hardware.

CONSULT FACTORY FOR OPTIONS



Jack Stands / 4,000 lbs. CAPACITY

The lift certified RS4 jack stand provides added assurance of vehicle lift safety.

Maximum height: 84" (2133mm)

Minimum height: 55 1/2" (1410mm)

Fine thread-up height:

1 5/8" to 7 1/8" (41mm to 181mm)

#RS4



MW-200 Tire Lift

200 lbs. capacity air operated tire and wheel lift. Provides maneuverability and adjustable lifting and lowering speeds.

- Quick transfers to tire balancers
- Easy positioning of the tire / wheel
- Includes air hose and auxiliary air tool connection

#MW-500

500 lbs. capacity model available



#MW-200

Wheel Wing™ Tire Arm

Handy for tire rotations and brake jobs, the 100 lbs. capacity Wheel Wing tire arm mounts easily on any column arm and holds a tire at lift arm height. Folds away when not in use.

- Adjustable to fit various lift arms
- Includes set of 2 arms, 2 magnetic lug nut dishes, shims



#FA5974

Door Defender™

The door defender is a low profile solid rubber guard designed to fit over the two-post lift carriage.

Allows technicians to easily enter and exit the vehicle without vehicle damage.

Includes one (1) padded defender, and adhesive.

#N823



Column Base Plate Cover

Refresh your shop's appearance with a unique accessory from Rotary Lift designed to cover the base plates on popular two-post lift models.

Keep mounting hardware

hidden, safely enclosed and

protected. Base plate covers fit standard

Rotary Lift SPOA10, SPOA9 and SPOA7

(200 series and above) lifts.

#N539



Accessories shown may be used with most frame contact models. Accessories for FA adapters fit any surface mounted, frame engaging Rotary Lift manufactured since October of 1973. Consult your Rotary Authorized Distributor for more information concerning these accessory options.

Lock Light™ - patent pending

Provides an instant green light visual confirmation when lift is **lowered to its locks**. Compatible with most surface and high-pressure lifts that use an electric/hydraulic power unit providing an unused pressure port is available.

Kit includes:

- Indicator light assembly
- Pressure switch
- Mounting bracket
- 10' of electrical wire



#FA834 / 110V
#FA835 / 220V

TECH LIGHT™ Line Light 2

Attach the 2 ultra slim light wands to columns for effective, efficient 2-post lighting where you need it. Supplied with 4 magnetic clips for easy positioning.

Includes:

- (2) 96 LED lights with 25' of cable and 20W power supply
- 3" spiral cords - stretches to 16" for placement under vehicle
- Magnetic junction box
- Input voltage 100-240 V AC

#FA5701



TECH LIGHT™ Line Light R

Rechargeable LED inspection hand lamp with top spot light. Supplied with flexible suspension clips holder with both hook and magnet for positioning the light exactly where you need it

Additional suspension solutions available as accessories.

- 180 lumen in main light operates for up to 3 hours
- 120 lumen in spot light operates for up to 6 hours
- 4 hour charging time



#FA5702

TWO-POST STANDARD / OPTIONAL LIFT FEATURES

FEATURE	Standard Feature ●	Optional Feature ○	AT07 7,700 lbs.	SPOA7 7,000 lbs.	SP010 10,000 lbs.	SPOA10 10,000 lbs.	SP012 12,000 lbs.	SP016 16,000 lbs.	SP020 20,000 lbs.
	Lift column design			Asymmetric	Asymmetric	Symmetric	Asymmetric	Symmetric	Symmetric
ALI Certified	●		●	●	●	●	●	●	●
Surface mounted models	●		●	●	●	●	●	●	●
SHOCKWAVE™ Equipped models		N/A	N/A	○	○	○	○	○	○
3-stage TRIO™ arms		N/A	N/A	N/A	N/A	●	N/A	●	●
Conventional 3-stage arms		N/A	N/A	N/A	○	N/A	●	N/A	N/A
Multiple contact / adapter options		○	○	N/A	○	○	N/A	●	●
3-phase power units		○	○	○	○	○	○	○	○
Single point lock release	●		●	●	●	●	●	●	●
Multi-position locking systems	●		●	●	●	●	●	●	●
Original single piece "Double S" column construction		N/A	N/A	●	●	●	●	●	●
Hydraulic cylinders in each column	●		●	●	●	●	●	●	●
Overhead cables / clear floor design	●		●	●	●	●	●	●	●
Seismic rated column baseplate		N/A	N/A	○	○	○	○	○	○
Adjustable narrow column width		N/A	N/A	N/A	○	○	N/A	N/A	N/A
Adjustable wider column width		N/A	N/A	N/A	N/A	N/A	○	○	○
Extended higher rise option		N/A	N/A	N/A	○	○	○	○	○
Extended overhead height options		N/A	N/A	N/A	○	○	○	○	○
Low ceiling model available		N/A	N/A	N/A	N/A	N/A	○	○	○
Automatic arm restraints	●		●	●	●	●	●	●	●
Overhead padded switch bar	●		●	●	●	●	●	●	●
Multi-position wheel spotting dish	●		●	●	●	●	●	●	●



LIFT APPLICATION GUIDE



VEHICLE CLASS

GVW:
Gross Vehicle Weight



CLASS 1
Under 6,000 lbs. GVW



CLASS 2
6,001 to 10,000 lbs. GVW



CLASS 3
10,001 to 14,000 lbs. GVW



CLASS 4
14,001 to 16,000 lbs. GVW



CLASS 5
16,001 to 19,500 lbs. GVW



CLASS 6
19,501 to 26,000 lbs. GVW



CLASS 7
26,001 to 33,000 lbs. GVW



CLASS 8
33,001 lbs. and over GVW

	6,000 lbs.	7,000 lbs.	10,000 lbs.	8,000 lbs.	10,000 lbs.	12,000 lbs.	7,000 lbs.	10,000 lbs.	12,000 lbs.	16,000 lbs.	20,000 lbs.	12,000 lbs.	14,000 lbs.	18,000 lbs.	30,000 lbs.	40,000 lbs.	50,000 lbs.	60,000 lbs.	52,000 lbs.	72,000 lbs.	78,000 lbs.	108,000 lbs.	144,000 lbs.	30,000 lbs.	36,000 lbs.	45,000 lbs.	50,000 lbs.	75,000 lbs.	100,000 lbs.	60,000 lbs.	70,000 lbs.	90,000 lbs.	105,000 lbs.		
CLASS 1	•	•	•	•	•	•	•	•	•	•	•	•	•	•	•	•	•	•	•	•	•	•	•	•	•	•	•	•	•	•	•	•	•	•	•
CLASS 2		•		•	•			•	•	•	•	•	•	•	•	•	•	•	•	•	•	•	•	•	•	•	•	•	•	•	•	•	•	•	•
CLASS 3										•	•	•		•	•	•	•	•	•	•	•	•	•	•	•	•	•	•	•	•	•	•	•	•	•
CLASS 4										•	•			•	•	•	•	•	•	•	•	•	•	•	•	•	•	•	•	•	•	•	•	•	•
CLASS 5											•			•	•	•	•	•	•	•	•	•	•	•	•	•	•	•	•	•	•	•	•	•	•
CLASS 6															•	•	•	•	•	•	•	•	•	•	•	•	•	•	•	•	•	•	•	•	•
CLASS 7															•	•	•	•	•	•	•	•	•	•	•	•	•	•	•	•	•	•	•	•	•
CLASS 8															•	•	•	•	•	•	•	•	•	•	•	•	•	•	•	•	•	•	•	•	•

NOTE: This reference guide indicates that the noted lift is applicable to the vehicle based on typical vehicle weights, lengths and wheelbases. All information should be verified before purchasing a lift.



Rotary Lift
2700 Lanier Drive
Madison, IN 47250, USA



North / South America Contact Information

Sales: p 800.640.5438
e userlink@rotarylif.com
Tech. Support: p 800.445.5438
e techlink@rotarylif.com

Global Contact Information

USA: 1.812.273.1622
Canada: 1.905.812.9920
Latin America / Caribbean: 1.812.273.1622
Brazil: +55.11.4534.1995

Assistance for Government Purchasing

Government Sales: 800.445.5438 X5655



FSS Contract No. GS07F294AA



Contract No. 05316



Contract No. 061015-RRL



Lit# Rotary_2Post Brochure_2018.09 (SUPERCEDES Lit# Rotary_2Post Brochure_2018.06)

©2018 VEHICLE SERVICE GROUP™, Printed in U.S.A., All Rights Reserved. Unless otherwise indicated, ROTARY LIFT, VEHICLE SERVICE GROUP™, DOVER and all other trademarks are property of Dover Corporation and its affiliates.

Trio Arms™ (US Patent No. 8,973,712 / US Patent No. 9,550,658)

For additional world wide contact information and a complete guide to our product offering, visit us on the web at rotarylif.com.